

SAFE-T-PULL[®] P/N STP - M INSTALLATION & SETTING INSTRUCTIONS

YELLOW INDICATION FLAG:
P/N STP-F

The Indication Flag should be fitted when there is more than one switch used on the conveyor as noted in AS1755-2000 Clause 2.7.9.1 (e)

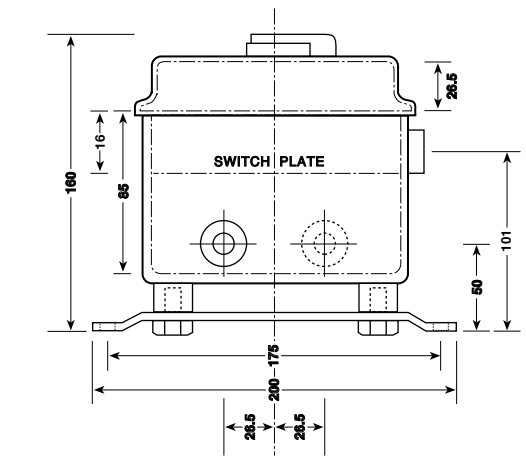
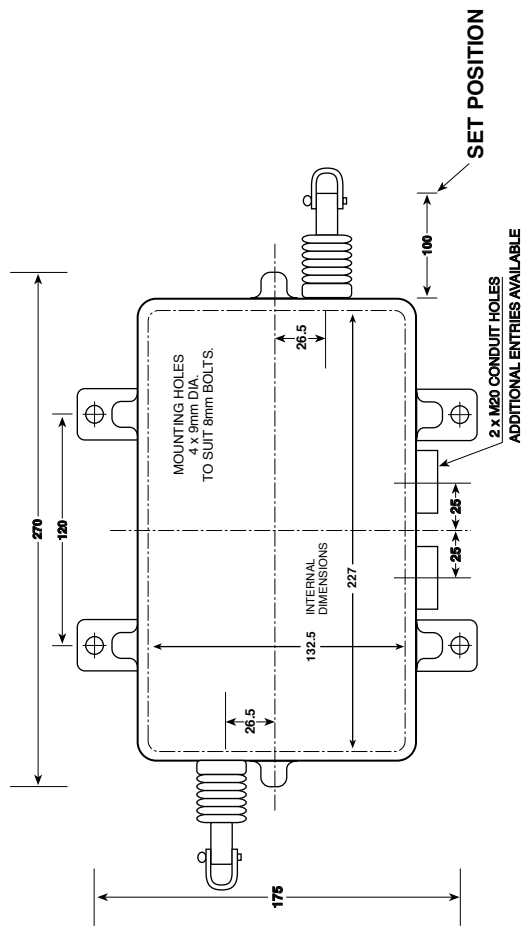
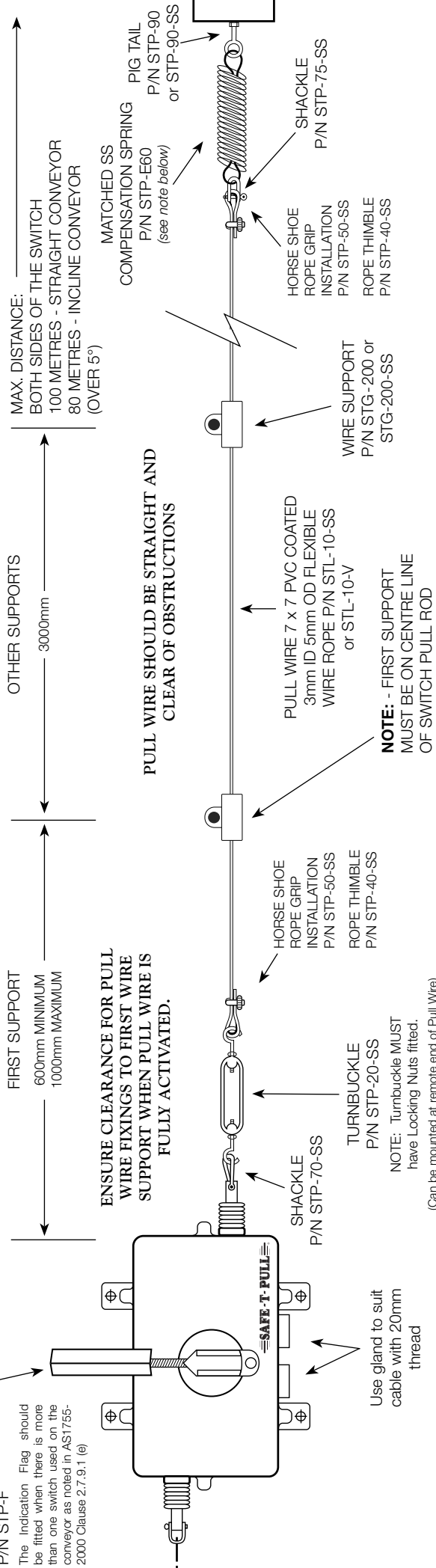

For further requirements refer to AS 4024-1-2006 "Safeguarding of Machinery" Part 1: General principals and AS 1755-2000 "Conveyors Design, Construction, Installation and Operation, Safety requirements," respectively for conveyors used in Australia.

NOTE: TO COMPLY WITH AS 1755-2000 Clause 2.7.9

A matched compensation spring must be fitted to the remote end of the Pull Wire to allow tripping in both directions. AS 1755-2000 is the Australian Standards for Conveyor - Safety Requirements.



ACN: 060 617 987



SWITCH CANNOT BE RESET UNTIL BOTH PULL WIRES ARE CORRECTLY TENSIONED TO THE SET POSITION

ie. 100mm from pull rod end to switch body.

SAFE-T-PULL

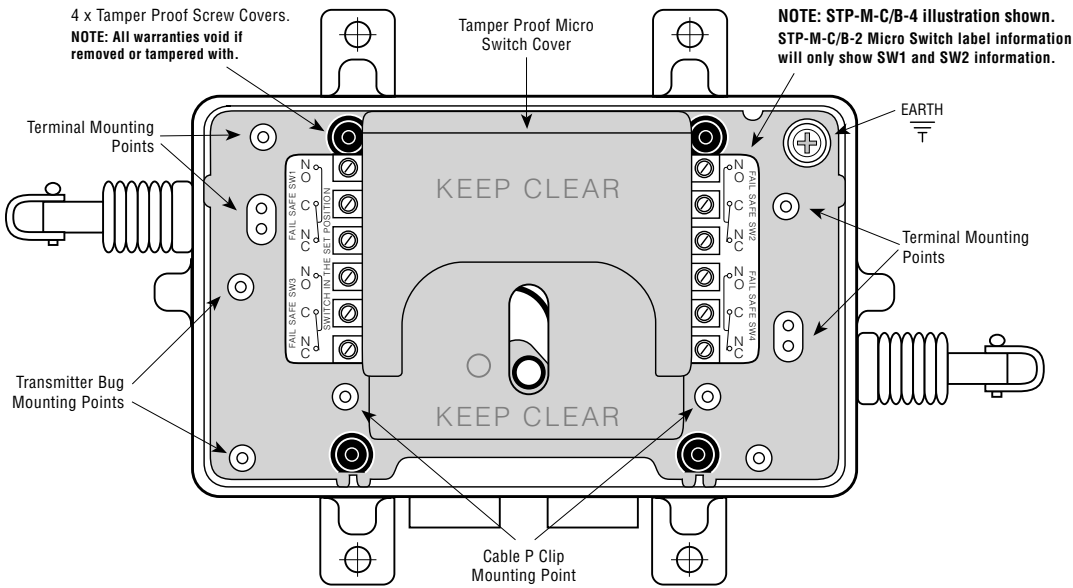

NOTE:

Fail Safe Micro Switch SW 1 and SW 2 fitted in STP-M-C-2 / STP-M-B-2

Fail Safe Micro Switch SW 1, SW 2, SW 3 and SW 4 fitted in STP-M-C-4 / STP-M-B-4

General Characteristics

Comply with		IEC / EN61058, UL 1054
Rated Insulation voltage U_i	V	250V
Rated impulse withstand voltage U_{imp}	V	1500
Rated thermal current I_{th}	A	8
Rated operating current I_e :	ac	8A - 250V resistive load, 3A -250V inductive load
Ambient temperature	°C	-25 +85
Electric shock protection		Class II
Pollution class		2
Life	cycles	Mechanical 10^6 , electrical 5×10^5
Termination type		6.3 x 0.8 faston terminal

- Changeover contacts.
- High reliability snap action contacts.
- Silver alloy self cleaning contacts, or Gold Flash available.
- Positive opening NC contact.

SAFE-T-PULL

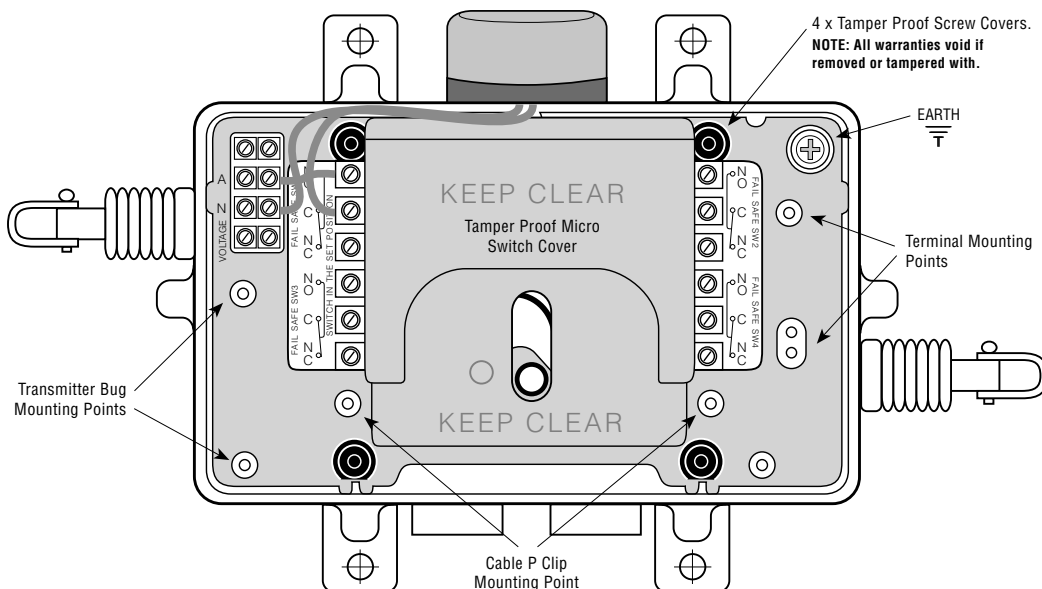

NOTE:

Fail Safe Micro Switch SW 1 and SW 2 fitted in STP-M-C-2 / STP-M-B-2

Fail Safe Micro Switch SW 1, SW 2, SW 3 and SW 4 fitted in STP-M-C-4 / STP-M-B-4

WIRING NOTE:

All wires to be kept away from the Tamper Proof Micro Switch Cover. See the "Keep Clear" info on the Cover.

P/N STP-M

Standards

The **SAFE-T-PULL** complies with the relevant parts of these Standards:

IEC 60947-5-1:2003	Control circuit devices & switching elements
AS 60947-5-1:2004	Control circuit devices & switching elements
IEC 60947.5:1997	Control circuit devices & switching elements-Electrical emergency stop devices with mechanical latching function.
AS 3947.5.5:2000	Control circuit devices & switching elements-Electrical emergency stop devices with mechanical latching function.
AS 4024.1-2006	Safety of Machinery.
AS 1755-2000	Conveyors-Safety requirements.

Ce Conformity to:

98/37/EEC	Machinery Directive
73/23/EEC	Low Voltage Directive

Harmonised Standards:

EN ISO 12100	Parts 1 & 2 Safety of machinery
EN 60204-1:1997	Safety of Machinery-Electrical equipment of machines
EN 418:1992	Safety of machinery-Emergency stop equipment

Workshop Tested

All switches are tested by trained personnel before leaving ELECTRIC CONTROL PRODUCTS and have a date & name label of manufacture so that all relevant Standards are complied with and the product is in a full working order.

Modifications of Switch

Any modifications are **ONLY** to be made by ELECTRIC CONTROL PRODUCTS or one of their registered repairers. Any unauthorised modifications may not comply with the relevant standards and may diminish the integrity and workings of the switch and the warranty will become void.

ELECTRIC CONTROL PRODUCTS and their registered repairers or distributors will not be responsible for any damage caused to the altered switch or any item in, on, related or near the switch, nor any injury incurred, nor actions resulting from the unauthorised alterations.

Returns Policy/ Re Stocking

Please return any defective switch to place of purchase for assessment. If they are deemed to be warranty repairs or not. Return warranty switches as per warranty clause. Restocking returns will only be accepted if received by ELECTRIC CONTROL PRODUCTS in their original condition and within thirty (30) days of delivery date stated on delivery documentation. A restocking fee applies (contact place of purchase for costs).

Warranty

Electric Control Products of Unit 2, 172 Beringarra Avenue, Malaga Perth Western Australia contact telephone: (08) 9249 1044 or sales@safe-t-prodcuts.com.au warranty period is **twelve (12) months** from date of purchase or longer if indicated by Electric Control Products. For warranty to be valid the goods must be received by Electric Control Products before the end of the twelve (12) month period. Electric Control Products warrants that if any product is defective, it will, at its option, replace or repair the product. **This warranty shall not apply to any defect which arises from improper use, failure to follow the products instruction, or any repair or modification made without the consent of Electric Control Products.**

The customer must contact the Distributor of the product or Electric Control Products of Unit 2, 172 Beringarra Avenue, Malaga Perth Western Australia via telephone: (08) 9249 1044 or Email sales@safe-t-prodcuts.com.au before returning the faulty product. If returned they must be suitably packaged and, where relevant, returned in accordance with any particular instructions which Electric Control Products or one of its distributors may have notified the customer at the time of contact for warranty. **Returned products must be accompanied by an advice note stating the nature of any defect being claimed.** Any products or parts which are replaced by Electric Control Products or one of its distributors shall become the property of Electric Control Products. **Title to replacement products shall pass to the customer on delivery, and the period of the warranty shall be calculated from the date of the defective product.**

All warranty returns to Electric Control Products will be sent by the customer's freight at their cost. All benefits under this warranty are in addition to other rights and remedies of the consumer under a law in relation to the goods or services to which the warranty relates. Our goods come with guarantees that cannot be excluded under the Australian Consumer Law. You are entitled to a replacement or refund for a major failure and for compensation for any other reasonably foreseeable loss or damage. You are also entitled to have the goods repaired or replaced if the goods fail to be of acceptable quality and the failure does not amount to a major failure.

P/N STP-M

Product Life Expectancy

Electric Control Products **estimate** the product life expectancy to 10-15 years.

A shorter or longer product life maybe experienced due to environmental situations.

Electric Control Products can't give a written life expectancy on any of it's products due to the different situations the products are used.

Technical Support

Technical advice will be given at any time by Electric Control Products or Distributor on any of the Electric Control Product range. Contact Electric Control Products or your local Distributor for this service.

Obsolete Products

Notification will be given to Distributors only for the products becoming obsolete and a time frame of when this will occur. Please contact Distributors for this information.

The Obsolete product range will have spare parts for 12 months after becoming obsolete or until they run out, complete products will be available for a short time after it has become obsolete.

Maintenance Procedure

All **SAFE-T-PULL** switches require minimal maintenance but as in AS 4024.1:1996 & AS 1755:2000 maintenance procedure should be carried out.

Maintenance at 3 Month recommended intervals, or as per Applied Risk Assessment

1. Check that the switches are installed as per installation instructions.
2. Visual inspection of enclosure to ensure IP67 rating and correctly operating device. i.e. Damaged enclosure, bent pull rod, damaged dust boot etc.
3. Inspect compensation springs (Overall relaxed size is 213mm +/- 10mm)
4. Inspect all attachments are tight, free from obstructions and not worn and replace if necessary.
5. Inspect pull wire supports for wear, deterioration and build up of material, replace if necessary.
6. Inspect pull wire for wear or deterioration and replace if necessary.
7. Check that the pull rods are tensioned to the set position as per installation instructions.

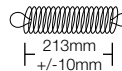
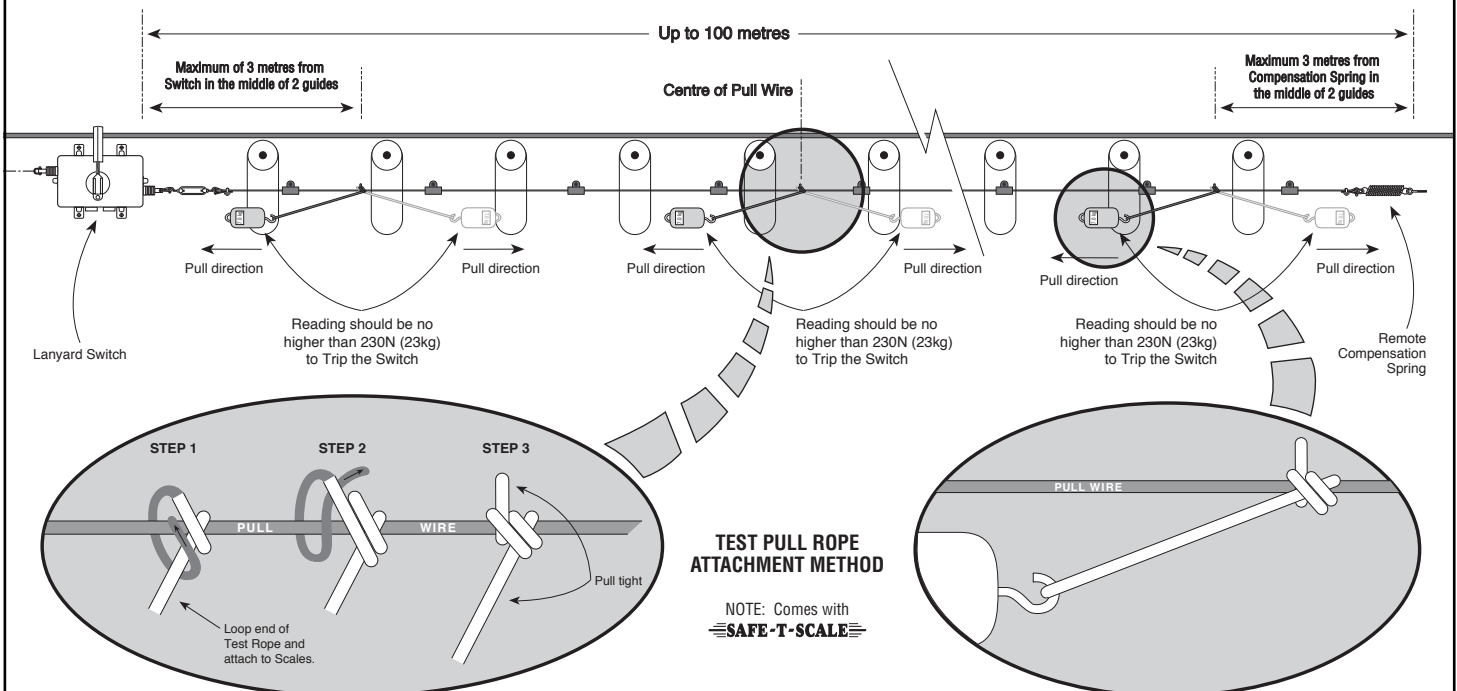

FIGURE 1
Axis Pull Wire Test



P/N STP-M

8. Test that the SAFE-T-PULL Lanyard works as per Australian Standards AS1755-2000

Attach the SAFE-T-SCALE or other weight measurement device to the pull wire via the SAFE-T-SCALE rope or other means (See Figure 1). The test needs to be conducted along the axis of the pull wire in both directions. Pull the wire along the axis until the switch trips then check the amount of force used to activate a trip. The reading must be less than 230N (23Kg). This must be done at intervals at the centre of pull wire's length, 3m-4m from the switch and 3m-4m from the compensation spring in both directions (See Figure 1). After each trip the switch will need to be reset before the next axis trip test is to be conducted. If the reading is higher than 230N then recheck steps 1-7, then retest the axis pull test. If the problem is still present contact the supplier of the product for advice.

Reset the SAFE-T-PULL and attach the SAFE-T-SCALE or other weight measurement device to the pull wire (See Figure 2), 90 degrees to the pull wire axis. A length measurement needs to be taken as well. The test needs to be conducted 90 degrees to the pull wire's axis at the same positions as test 1 and at the centre, between supports (See Figure 2). Pull the wire to the 90 degree axis and using the SAFE-T-SCALE or some other weight measurement device, measure the amount of force it takes to trip the switch. Once the switch trips check to see how far the pull wire needs to be pulled to activate a trip using a tape measure or ruler. The force used to activate a trip must not exceed 70N (7Kg) and the amount of pull must not exceed 300mm. If the readings are higher than 70N-300mm then recheck steps 1-7, retest the 90 degree axis pull test. If the problem is still present contact the supplier of the product for advice.

FIGURE 2
90 Degree Pull Wire Test

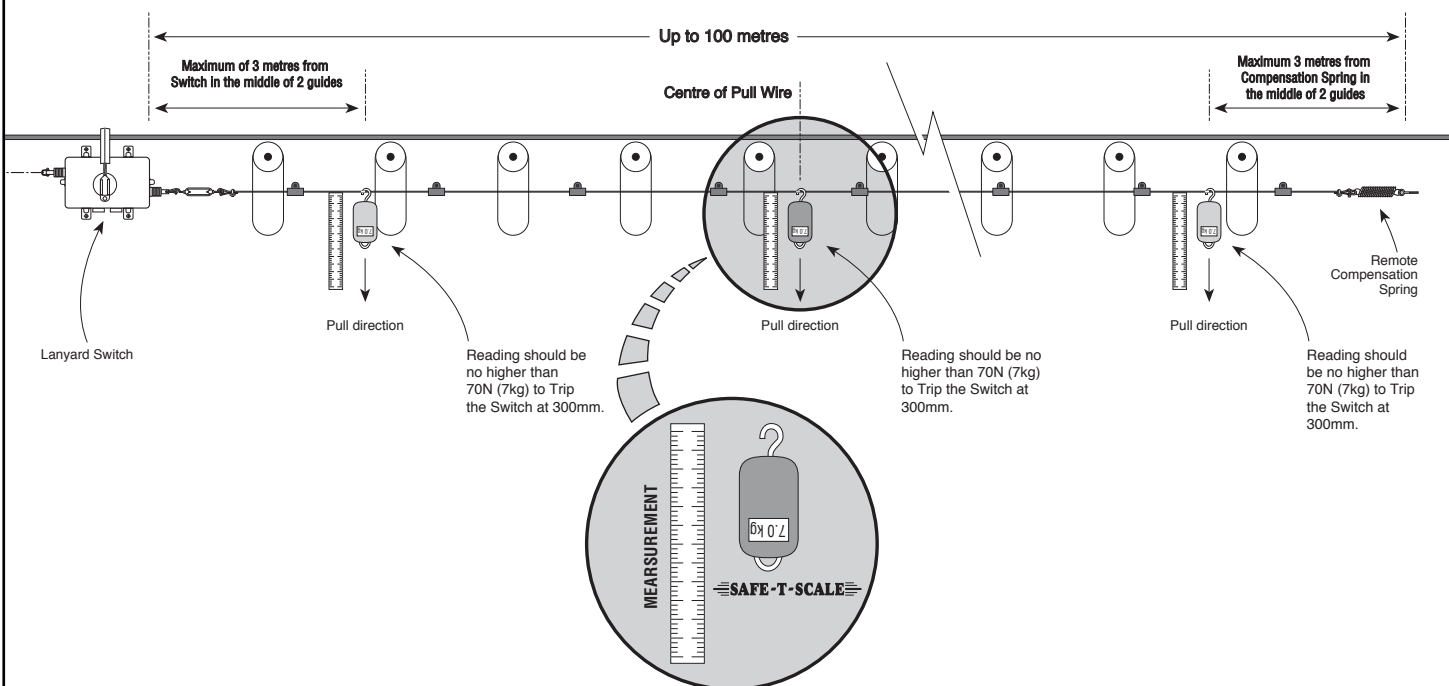

9. After activation test, check that the set position of the pull rods are as per installation instructions, if not readjust turnbuckle so the pull rods are at the set position and redo step 8-9.
10. If the switch is not working return to authorised distributor for assessment if under warranty or replace.

Every 12 Month Period

Remove cover & check for corrosion or water ingress. Replace if necessary.

Check electrical connections for security and corrosion.

Clean lid seal and replace cover & torque down lid screws as per limit switch wiring diagram.

This page has been left blank